

(5) GHW-CC / GHW-HC

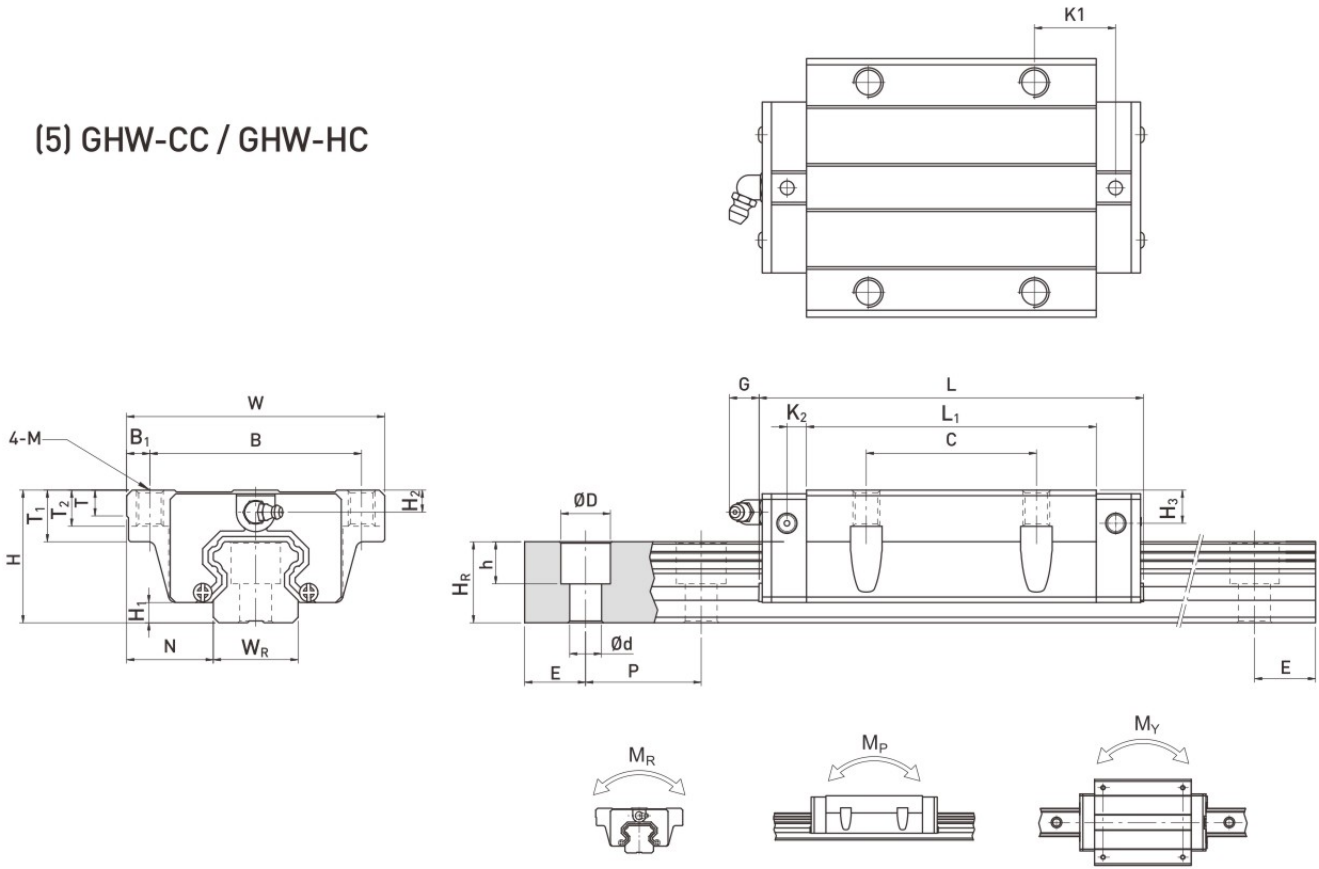

型號	組件尺寸 (mm)		滑塊尺寸 (mm)														滑軌尺寸 (mm)		滑軌的 固定螺 柱尺寸 (mm)	基本 動額 定負荷 C(kN)	基本 靜額 定負荷 C <sub>0</sub> (kN)	容許靜力矩			重量								
	H	H <sub>1</sub>	N	W	B	B <sub>1</sub>	C	L <sub>1</sub>	L	K <sub>1</sub>	K <sub>2</sub>	G	M	T	T <sub>1</sub>	T <sub>2</sub>	H <sub>2</sub>	H <sub>3</sub>				W <sub>R</sub>	H <sub>R</sub>	D	h	d	P	E	M <sub>R</sub>	M <sub>P</sub>	M <sub>Y</sub>	滑塊	滑軌
	mm	mm	mm	mm	mm	mm	mm	mm	mm	mm	mm	mm	mm	mm	mm	mm	mm	mm	mm	mm	mm	mm	mm	mm	mm	mm	kN-m	kN-m	kN-m	kg	kg/m		
GHW 15CC	24	4.3	16	47	38	4.5	30	39.5	60.5	8	4.85	5.3	M5	6	8.9	6.95	3.95	3.7	15	15	7.5	5.3	4.5	60	20	M4x16	11.38	16.97	0.12	0.10	0.10	0.17	1.45
GHW 20CC	30	4.6	21.5	63	53	5	40	50.5	76.7	10.25	6	12	M6	8	10	9.5	6	6	20	17.5	9.5	8.5	6	60	20	M5x16	17.75	27.76	0.27	0.20	0.20	0.40	2.21
GHW 20HC								65.2	91.4	17.6																	21.18	35.9	0.35	0.35	0.35	0.52	
GHW 25CC	36	5.5	23.5	70	57	6.5	45	58	84	10.7	6	12	M8	8	14	10	6	5	23	22	11	9	7	60	20	M6x20	26.48	36.49	0.42	0.33	0.33	0.59	3.21
GHW 25HC								78.6	104.6	21																	32.75	49.44	0.56	0.57	0.57	0.80	
GHW 30CC	42	6	31	90	72	9	52	70	98.4	14.25	6	12	M10	8.5	16	10	6.5	10.8	28	26	14	12	9	80	20	M8x25	38.74	52.19	0.66	0.53	0.53	1.09	4.47
GHW 30HC								93	121.4	25.75																	47.27	69.16	0.88	0.92	0.92	1.44	
GHW 35CC	48	7.5	33	100	82	9	62	80	112.4	14.6	7	12	M10	10.1	18	13	9	12.6	34	29	14	12	9	80	20	M8x25	49.52	69.16	1.16	0.81	0.81	1.56	6.30
GHW 35HC								105.8	138.2	27.5																	60.21	91.63	1.54	1.40	1.40	2.06	
GHW 45CC	60	9.5	37.5	120	100	10	80	97	137.4	13	10	12.9	M12	15.1	22	15	8.5	20.5	45	38	20	17	14	105	22.5	M12x35	77.57	102.71	1.98	1.55	1.55	2.79	10.41
GHW 45HC								128.8	169.2	28.9																	94.54	136.46	2.63	2.68	2.68	3.69	
GHW 55CC	70	13	43.5	140	116	12	95	117.7	166.7	17.35	11	12.9	M14	17.5	26.5	17	12	19	53	44	23	20	16	120	30	M14x45	114.44	148.33	3.69	2.64	2.64	4.52	15.08
GHW 55HC								155.8	204.8	36.4																	139.35	196.2	4.88	4.57	4.57	5.96	
GHW 65CC	90	15	53.5	170	142	14	110	144.2	200.2	23.1	14	12.9	M16	25	37.5	23	15	15	63	53	26	22	18	150	35	M16x50	163.63	215.33	6.65	4.27	4.27	9.17	21.18
GHW 65HC								203.6	259.6	52.8																	208.36	303.13	9.38	7.38	7.38	12.89	

註 : 1 kgf = 9.81 N